

Data sheet

Condensing pressure regulator, type KVR Differential pressure valve, type NRD



Regulating system KVR and NRD is used to maintain a constant and sufficiently high condenser and receiver pressure in refrigeration and air conditioning plant with air-cooled condensers.

KVR can also be used together with receiver pressure regulator, type KVD.

Features

- Accurate, adjustable pressure regulation
- Wide capacity and operating range
- Pulsation damping design
- Stainless steel bellows
- Compact angle design for easy installation in any position
- "Hermetic" brazed construction
- 1/4 in. Schrader valve for pressure gauge connection
- Available with flare and ODF solder connections
- KVR 12 - KVR 22 and NRD: May be used in the following EX range: Category 3 (Zone 2)

Data sheet | Condensing pressure regulator, type KVR and differential pressure valve, type NRD

Approvals

UL LISTED, file SA7200
EAC

Technical data

Refrigerants	R22, R1270*, R134a, R290*, R404A, R407A, R407C, R407F, R448A, R449A, R450A, R452A, R507A**, R513A, R600*, R600a* *KVR 12 - KVR 22 only **not applicable for NRD
Adjustment range	5 – 17.5 bar Factory setting = 10 bar
Maximum working pressure	KVR: PS/MWP = 28 bar NRD: PS/MWP = 46 bar
Maximum test pressure	KVR: Pe = 31 bar NRD: Pe = 60 bar
Medium temperature range	-45 – 130 °C
P-band	KVR 12 – 22 = 6.2 bar KVR 28 – 35 = 5 bar
Opening differential pressure for NRD	Start opening: $\Delta p = 1.4$ bar Fully open: $\Delta p = 3$ bar

This product (KVR 12 – KVR 22) is evaluated for R290, R600, R600a, R1270 by ignition source assessment in accordance with standard EN13463-1.

For complete list of approved refrigerants, visit www.products.danfoss.com and search for individual code numbers, where refrigerants are listed as part of technical data.

Ordering

KVR 12, KVR 15, KVR 22, KVR 28, KVR 35, NRD

Type	Rated liquid capacity ¹⁾ (Evaporator capacity) [kW]				Rated hot gas ¹⁾ (Evaporator capacity) [kW]				Flare connect. ²⁾		Code no.	Solder Connect.		Code no.
	R22	R134a	R404A/ R507	R407C	R22	R134a	R404A/ R507	R407C	[in]	[mm]		[in]	[mm]	
KVR 12	50.4	47.3	36.6	54.4	13.2	11.6	12.0	14.3	1/2	12	034L0091	1/2	–	034L0093
	50.4	47.3	36.6	54.4	13.2	11.6	12.0	14.3	–	–	–	–	12	034L0096
KVR 15	50.4	47.3	36.6	54.4	13.2	11.6	12.0	14.3	5/8	16	034L0092	5/8	16	034L0097
KVR 22	50.4	47.3	36.6	54.4	13.2	11.6	12.0	14.3	–	–	–	7/8	22	034L0094
KVR 28	129	121	93.7	139.3	34.9	30.6	34.9	37.7	–	–	–	1 1/8	–	034L0095
	129	121	93.7	139.3	34.9	30.6	34.9	37.7	–	–	–	–	28	034L0099
KVR 35	129	121	93.7	139.3	34.9	30.6	34.9	37.7	–	–	–	1 3/8	35	034L0100
NRD	–	–	–	–	–	–	–	–	–	–	–	1/2	–	020-1132
	–	–	–	–	–	–	–	–	–	–	–	–	12	020-1136

The connection dimensions chosen must not be too small, since gas velocities in excess of 40 m/s at the inlet of the regulator can give flow noise.

- ¹⁾ Rated capacity is based on:
- evaporating temperature $t_e = -10$ °C
 - condensing temperature $t_c = 30$ °C
 - pressure drop across the valve
 $\Delta p = 0.2$ bar for liquid capacity
 $\Delta p = 0.4$ bar for hot gas capacity
 - offset = 3 bar

To select the product for other conditions or refrigerants, use Danfoss Coolselector*2.

- ²⁾ KVR are delivered without flare nuts. Separate flare nuts can be delivered:

- 1/2 in / 12 mm, code no. 011L1103
- 5/8 in / 16 mm, code no. 011L1167

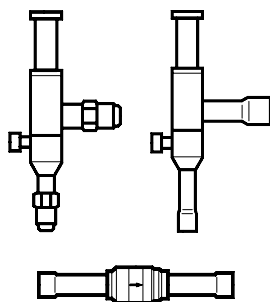

REACH requirements

All Danfoss products fulfill the requirements in REACH. One of the obligations in REACH is to inform customers about presence of Candidate list substances if any, we hereby inform you about one substance on the candidate list:

an O-ring used in this product contains Diisopentylphthalat (CAS no: 605-50-5) in a concentration above 0.1% w/w.

Liquid capacity

Max. regulator capacity Q_e ¹⁾

Type	Condensing temperature t_c	Liquid capacity in [kW] (Evaporator capacity)				
		Offset 1.5 bar				
	[°C]	0.1	0.2	0.4	0.8	1.6
R22						
KVR 12 KVR 15 KVR 22	10	23.7	33.5	47.4	67.0	94.8
	20	21.8	30.8	43.6	61.7	87.3
	30	19.8	28.1	39.7	56.2	79.4
	40	17.8	25.2	35.6	50.4	71.3
	50	15.7	22.2	31.4	44.4	62.9
KVR 28 KVR 35	10	60.5	85.6	121.1	171.2	242.3
	20	55.7	78.8	111.4	157.6	223.0
	30	50.7	71.7	101.4	143.4	202.9
	40	45.9	64.3	91.0	128.7	182.1
	50	40.1	58.8	80.3	113.6	160.7
R134a						
KVR 12 KVR 15 KVR 22	10	22.8	32.3	45.6	64.6	91.3
	20	20.8	29.4	41.6	58.8	83.2
	30	18.7	26.5	37.4	53.0	74.9
	40	16.6	23.5	33.2	47.0	66.5
	50	14.5	20.5	29.0	41.0	58.0
KVR 28 KVR 35	10	58.3	82.4	117.0	165.0	233.0
	20	53.1	75.1	106.0	150.0	213.0
	30	47.8	67.6	95.7	135.0	191.0
	40	42.5	60.0	84.9	120.0	170.0
	50	37.0	52.3	74.0	105.0	148.0

Liquid capacity in [kW] (Evaporator capacity)					
Offset 3 bar					
Pressure drop across valve Δp [bar]					
0.1	0.2	0.4	0.8	1.6	
R22					
42.5	60.2	85.1	120.4	170.5	
39.2	55.4	78.4	110.9	157.0	
35.6	50.4	71.3	100.9	142.9	
32.0	45.3	64.0	90.6	128.3	
28.2	39.9	56.4	79.9	113.1	
108.9	154.0	217.8	308.2	436.2	
100.2	141.8	200.6	283.8	401.7	
91.2	129.0	182.5	258.2	365.5	
81.9	115.8	163.9	231.8	328.2	
72.2	102.1	144.4	204.4	289.3	
R134a					
40.7	57.5	81.4	115.0	163.0	
37.1	52.5	74.2	105.0	149.0	
33.4	47.3	66.9	94.7	134.0	
29.7	42.0	59.4	84.1	119.0	
25.9	36.6	51.8	73.3	104.0	
104.0	147.0	208.0	295.0	418.0	
94.9	134.0	190.0	269.0	361.0	
85.5	121.0	171.0	242.0	343.0	
76.0	108.0	152.0	215.0	305.0	
66.3	93.7	133.0	188.0	266.0	

¹⁾ The capacities are based on:
 - Evaporating temperature $t_e = -10$ °C
 - For other evaporating temperatures see table below

Correction factors for evaporating temperature t_e

t_e	-40	-30	-20	-10	0	10
[°C]						
R22	1.09	1.05	1.02	1.0	0.98	0.96
R134a	1.14	1.09	1.04	1.0	0.96	0.93

Plant capacity x correction factor = table capacity

Liquid capacity
(continued)

Max. regulator capacity Q_e ¹⁾

Type	Condensing temperature t_c	Liquid capacity in [kW] (Evaporator capacity)				
		Offset 1.5 bar				
	[°C]	0.1	0.2	0.4	0.8	1.6
R404A / R507						
KVR 12 KVR 15 KVR 22	10	18.4	25.9	36.8	52.0	73.5
	20	16.4	23.2	32.9	46.5	65.7
	30	14.5	20.5	29.0	41.0	58.0
	40	12.9	17.6	25.0	35.4	50.1
	50	10.5	14.9	21.0	29.7	42.1
KVR 28 KVR 35	10	46.9	66.3	93.8	132.3	188.0
	20	42.0	59.3	83.9	118.7	168.0
	30	37.0	52.3	73.9	104.6	148.1
	40	31.9	45.2	63.8	90.3	128.1
	50	26.9	37.9	53.7	75.9	107.0
R407C						
KVR 12 KVR 15 KVR 22	10	25.6	36.2	51.2	72.6	102.3
	20	23.5	33.2	47.1	66.6	94.3
	30	21.4	30.3	42.9	60.7	85.7
	40	19.4	27.5	38.8	55.0	77.7
	50	17.3	24.4	34.5	48.8	69.2
KVR 28 KVR 35	10	65.3	92.4	130.7	184.9	261.7
	20	60.1	85.1	120.3	170.2	240.8
	30	54.5	77.4	109.5	154.9	219.1
	40	50.0	70.1	99.2	140.3	198.5
	50	44.1	62.5	88.3	124.9	176.8

Liquid capacity in [kW] (Evaporator capacity)					
Offset 3 bar					
Pressure drop across valve Δp [bar]					
0.1	0.2	0.4	0.8	1.6	
R404A / R507					
32.9	46.4	65.6	92.9	131.3	
29.4	41.6	58.8	83.2	117.6	
25.9	36.6	51.8	73.3	103.7	
22.4	31.6	44.7	63.3	89.7	
18.8	26.6	37.6	53.2	75.4	
84.0	118.7	168.0	237.3	337.1	
75.2	106.1	150.2	213.2	301.4	
66.3	93.7	132.3	188.0	265.7	
57.2	81.0	114.5	161.7	228.9	
48.1	68.0	96.2	136.5	193.2	
R407C					
45.9	65.0	91.9	130.0	184.1	
42.3	59.8	84.7	119.8	169.6	
38.4	54.4	77.0	109.0	154.3	
34.9	49.4	69.8	98.8	139.8	
31.0	43.9	62.0	87.9	124.4	
117.6	166.3	235.2	332.9	471.1	
108.2	153.1	216.6	306.5	433.8	
98.5	139.3	197.1	278.9	394.7	
89.3	126.2	178.7	252.7	357.7	
79.4	112.3	158.8	224.8	318.2	

¹⁾ The capacities are based on:
 - Evaporating temperature $t_e = -10$ °C
 - For other evaporating temperatures see table below

Correction factors for evaporating temperature t_e

t_e [°C]	-40	-30	-20	-10	0	10
R404A / R507	1.18	1.11	1.05	1.0	0.95	0.92
R407C	1.12	1.08	1.04	1.0	0.97	0.93

Plant capacity x correction factor = table capacity

Hot gas capacity

Max. regulator capacity Q_e 1)

Type	Condensing temperature t_c [°C]	Hot gas capacity in [kW] (Evaporator capacity)				
		Offset 1.5 bar				
		Pressure drop across valve Δp [bar]				
		0.1	0.2	0.4	0.8	1.6
R22						
KVR 12 KVR 15 KVR 22	10	3.3	4.6	6.4	8.8	11.8
	20	3.5	5.0	6.9	9.6	13.0
	30	3.7	5.3	7.4	10.3	14.4
	40	3.9	5.5	7.8	10.9	15.0
	50	4.1	5.7	8.1	11.3	15.7
KVR 28 KVR 35	10	8.5	11.9	16.6	22.8	30.3
	20	9.1	12.8	17.9	24.8	33.5
	30	9.7	13.6	19.1	26.6	36.3
	40	10.2	14.3	20.1	28.1	38.7
	50	10.5	14.9	20.9	29.2	40.4
R134a						
KVR 12 KVR 15 KVR 22	10	2.9	4.0	5.6	7.6	9.7
	20	3.1	4.3	6.0	8.2	10.8
	30	3.2	4.5	6.3	8.8	11.7
	40	3.4	4.7	6.6	9.2	12.5
	50	3.4	4.8	6.8	9.5	13.0
KVR 28 KVR 35	10	7.5	10.5	14.5	19.6	25.0
	20	7.9	11.1	15.5	21.2	27.8
	30	8.4	11.8	16.4	22.6	30.2
	40	8.7	12.2	17.1	23.7	32.1
	50	8.9	12.5	17.6	24.5	33.5

Hot gas capacity in [kW] (Evaporator capacity)				
Offset 3 bar				
Pressure drop across valve Δp [bar]				
0.1	0.2	0.4	0.8	1.6
R22				
6.0	8.4	11.8	16.3	22.2
6.3	8.9	12.5	17.4	23.9
6.6	9.4	13.2	18.4	25.4
6.9	9.8	13.7	19.3	26.7
7.1	10.1	14.2	20.0	27.7
15.8	22.2	31.1	43.2	58.7
16.7	23.5	33.1	46.1	63.1
17.6	24.8	34.9	48.7	67.2
18.3	25.9	36.4	51.0	70.6
18.9	26.6	37.5	52.6	73.2
R134a				
5.4	7.6	10.7	14.7	19.6
5.6	7.9	11.1	15.4	20.8
5.8	8.2	11.6	16.1	21.9
6.0	8.5	11.9	16.6	22.8
6.1	8.6	12.1	16.9	23.3
14.4	20.2	28.2	38.8	51.8
15.0	21.0	29.5	40.8	55.0
15.5	21.8	30.6	42.5	57.9
15.9	22.4	31.5	43.9	60.3
16.1	22.7	32.0	44.7	61.7

1) The capacities are based on:
 - Evaporating temperature $t_e = -10$ °C
 - For other evaporating temperatures see table below

Correction factors for evaporating temperature t_e

t_e [°C]	-40	-30	-20	-10	0	10
R22	1.09	1.05	1.02	1.0	0.98	0.96
R134a	1.14	1.09	1.04	1.0	0.96	0.93

Plant capacity x correction factor = table capacity

Hot gas capacity
(continued)

Max. regulator capacity Q_e ¹⁾

Type	Condensing temperature t_c [°C]	Hot gas capacity in [kW] (Evaporator capacity)				
		Offset 1.5 bar				
		Pressure drop across valve Δp [bar]				
		0.1	0.2	0.4	0.8	1.6
R404A / R507						
KVR 12 KVR 15 KVR 22	10	3.2	4.5	6.3	8.6	11.7
	20	3.4	4.7	6.6	9.2	12.4
	30	3.5	4.9	6.8	9.5	13.0
	40	3.5	4.9	6.8	9.6	13.1
	50	3.5	4.9	6.8	9.6	13.1
KVR 28 KVR 35	10	8.3	11.7	16.2	22.3	30.0
	20	8.7	12.2	17.1	23.7	32.2
	30	8.9	12.5	17.6	24.4	33.5
	40	9.0	12.6	17.8	24.8	33.0
	50	9.0	12.6	17.8	24.8	33.5
R407C						
KVR 12 KVR 15 KVR 22	10	3.6	5.0	6.9	9.5	12.8
	20	3.8	5.4	7.5	10.4	14.0
	30	4.0	5.8	8.0	11.1	15.5
	40	4.2	6.0	8.5	11.9	16.4
	50	4.5	6.3	8.9	12.4	17.3
KVR 28 KVR 35	10	9.2	12.9	17.9	24.7	32.7
	20	9.8	13.8	19.3	26.8	36.2
	30	10.5	14.7	20.6	28.7	39.2
	40	11.1	15.6	21.9	30.6	42.2
	50	11.6	16.4	23.0	32.1	44.4

Hot gas capacity in [kW] (Evaporator capacity)				
Offset 3 bar				
Pressure drop across valve Δp [bar]				
0.1	0.2	0.4	0.8	1.6
R404A / R507				
5.8	8.1	11.3	15.8	21.6
6.1	8.4	11.8	16.5	22.7
6.1	8.5	12.0	16.8	23.2
6.1	8.6	12.1	16.9	23.2
6.1	8.6	12.1	16.9	23.2
15.8	22.2	31.1	43.2	58.7
16.7	23.5	33.1	46.1	63.1
17.6	24.8	34.9	48.7	67.2
18.3	25.9	36.4	51.0	70.6
18.9	26.6	37.5	52.6	73.2
R407C				
6.5	9.1	12.7	17.6	24.0
6.8	9.6	13.5	18.8	25.8
7.1	10.2	14.3	19.9	27.4
7.5	10.7	14.9	21.0	29.1
7.8	11.1	15.6	22.0	30.5
17.1	24.0	33.6	46.7	63.4
18.0	25.4	35.7	49.8	68.1
19.0	26.8	37.7	52.6	72.6
19.9	28.2	39.7	55.6	77.0
20.8	29.3	41.3	57.9	80.5

¹⁾ The capacities are based on:
 - Evaporating temperature $t_e = -10$ °C
 - For other evaporating temperatures see table below

Correction factors for evaporating temperature t_e

t_e [°C]	-40	-30	-20	-10	0	10
R404A / R507	1.18	1.11	1.05	1.0	0.95	0.92
R407C	1.12	1.08	1.04	1.0	0.97	0.93

Plant capacity x correction factor = table capacity

Sizing

For optimum performance, it is important to select a KVR valve according to system conditions and application.

The following data must be used when sizing a KVR valve:

- Refrigerant: HCFC, HFC and HC: KVR 12 – KVR 22, HCFC and non-flammable HFC: KVR 28 – KVR 35
- Evaporator capacity Q_e (plant capacity)
- Evaporating temperature t_e in [°C]
- Condensing temperature t_c in [°C]
- Connection type: flare or solder
- Connection size in [in]

Valve selection

Example

When selecting the appropriate valve it may be necessary to convert the actual evaporator capacity using a correction factors. This is required when your system conditions are different than the table conditions. The selection is also dependant on the acceptable pressure drop across the valve. The following example illustrates how this is done.

KVR in a liquid capacity application

- Refrigerant: R22 example
- Evaporator capacity: $Q_e = 100$ kW (plant capacity)
- Evaporating temperature: $t_e = -40$ °C
- Condensing temperature: $t_c = 30$ °C
- Connection type: Solder
- Connection size: $\frac{5}{8}$ in

Application example

Liquid capacity application

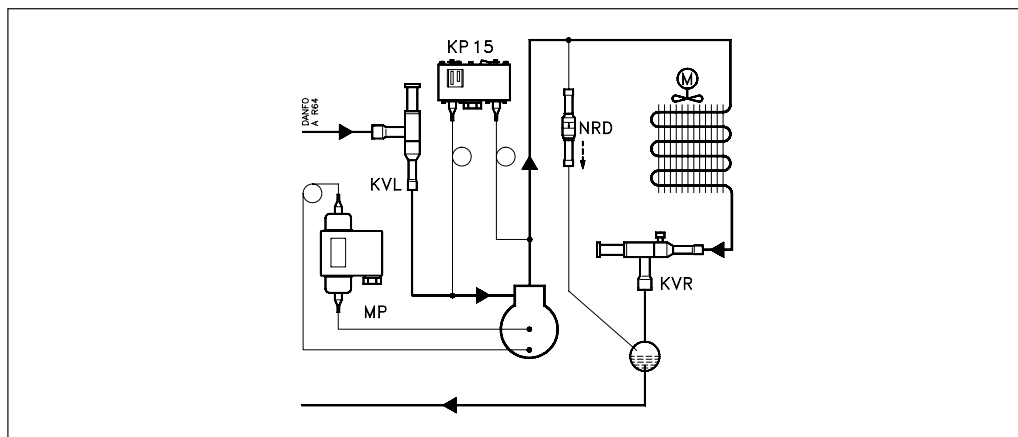

Application example

Liquid capacity application

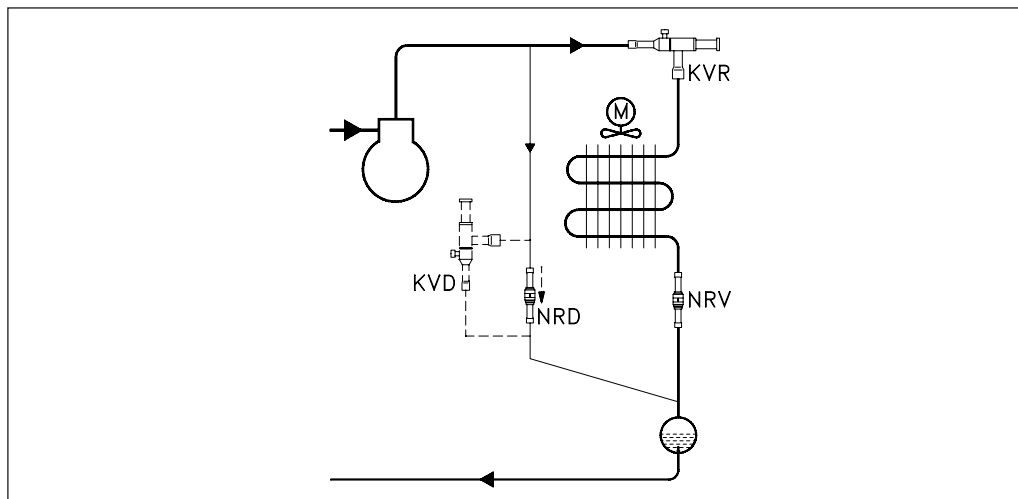

**Valve selection
(continued)**

Step 1

Determine the correction factor for evaporating temperature t_e .

From the correction factors table an evaporating temperature of $-40\text{ }^\circ\text{C}$, R22 corresponds to a factor of 1.09.

Correction factors

t_e [$^\circ\text{C}$]	-40	-30	-20	-10	0	10
R22	1.09	1.05	1.02	1.0	0.98	0.96
R134a	1.14	1.09	1.04	1.0	0.96	0.93
R404A, R507	1.18	1.11	1.05	1.0	0.95	0.92
R407C	1.12	1.08	1.04	1.0	0.97	0.93

Plant capacity x correction factor = table capacity

Step 2

Corrected evaporator capacity is

$$Q_e = 100 \times 1.09 = 109.0 \text{ kW}$$

Step 3

Now select the appropriate capacity table and choose the line for a condensing temperature $t_c = 30\text{ }^\circ\text{C}$.

Using the corrected evaporator capacity, select a valve that provides an equivalent or greater capacity at an acceptable pressure drop.

KVR 12, KVR 15, KVR 22 delivers 142.9 kW at 1.6 bar pressure drop across the valve.

Based on the required connection size of $\frac{5}{8}$ in. ODF, the KVR 15 is the proper selection for this example.

Step 4

KVR 15, $\frac{5}{8}$ in. solder connection:
code no. **034L0097** (see ordering list)

Design / Function

KVR

NRD

1. Seal cap
2. Gasket
3. Setting screw
4. Main spring
5. Valve body
6. Equalizing bellows
7. Valve plate
8. Valve seat
9. Damping device
10. Pressure gauge connection
11. Cap
12. Gasket
13. Insert
14. Piston
15. Valve plate
16. Piston guide
17. Valve body
18. Spring

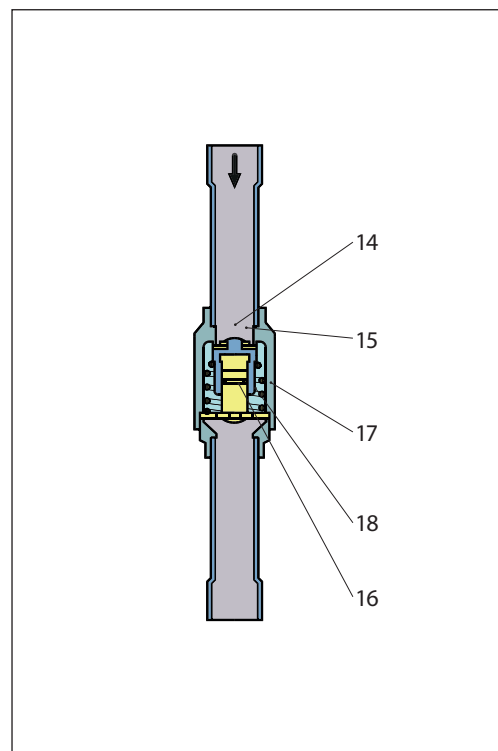
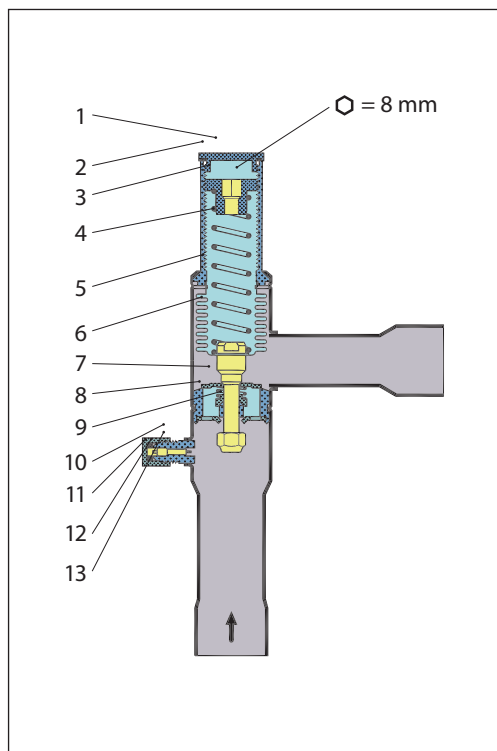

Condensing pressure regulator, type KVR opens upon a rise in pressure on the inlet side, i.e. when the pressure in the condenser reaches the set value. KVR regulation is dependent only on the inlet pressure. Pressure variations on the outlet side of the regulator do not affect the degree of opening, since type KVR has an equalizing bellows (6). The effective area of this bellows corresponds to that of the valve seat.

In addition, the regulator is equipped with an effective damping device (9) to safe-guard against pulsations which can normally occur in refrigeration plant.

The damping device contributes to ensuring a long working life for the regulator without impairing regulation accuracy.

Differential valve type NRD begins to open when the pressure drop in the valve is 1.4 bar, and is fully open when the pressure drop is 3 bar.

P-band and Offset

Principle diagram

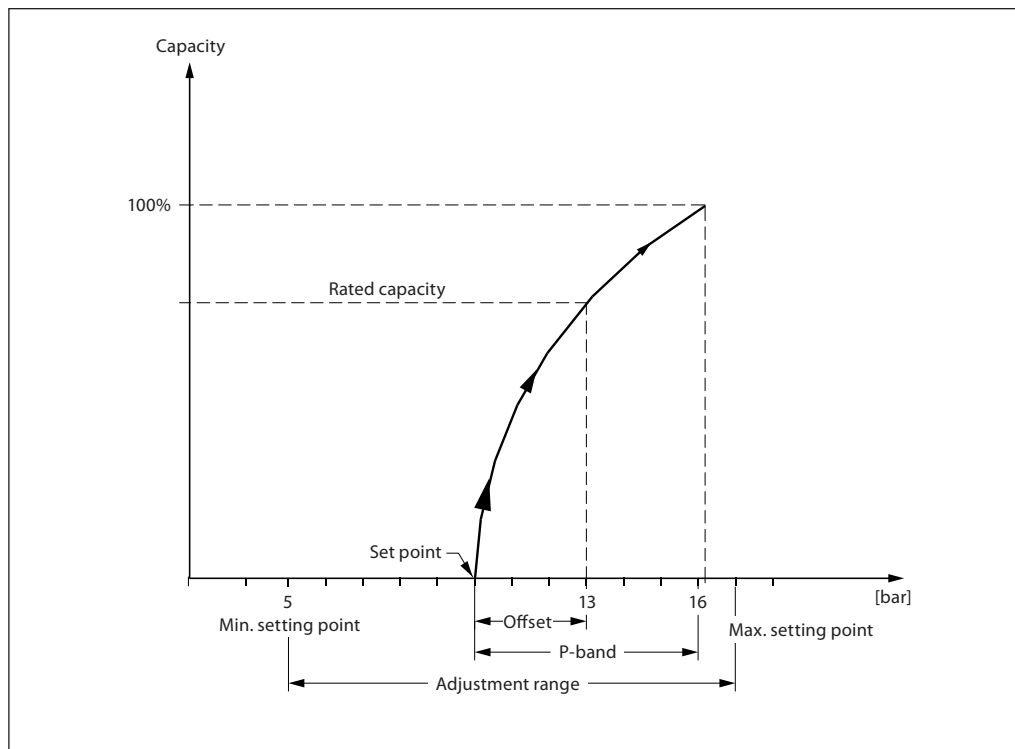

Proportional band

The proportional band or P-band is defined as the amount of pressure required to move the valve plate from closed (set point) to fully open position.

Example

If the valve is set to open at 10 bar and the valve P-band is 6.2, the valve will give maximum capacity when the inlet pressure reaches 16.2 bar.

Offset

The offset is defined as the amount of pressure required to move the valve plate from closed position (set point) to the necessary opening degree for the actual load. The offset is always a part of the P-band.

Example with R22

A working temperature of 36 °C ~ 13 bar is required, and the temperature must not drop below 27 °C ~ 10 bar (set point). The offset will then be 3 bar.

Dimensions and weights

KVR

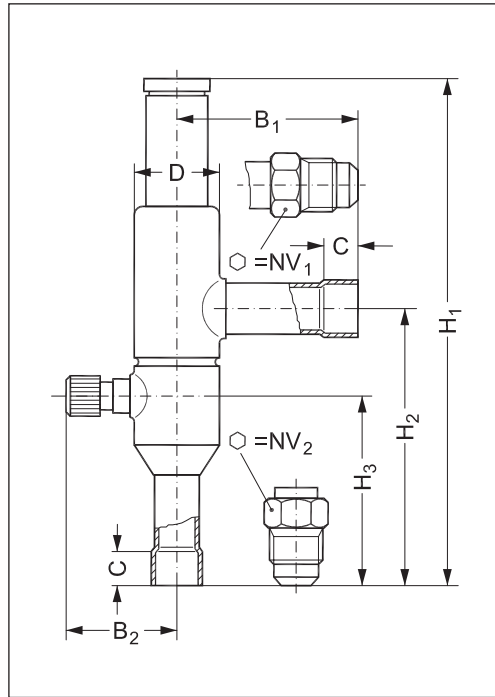

NRD

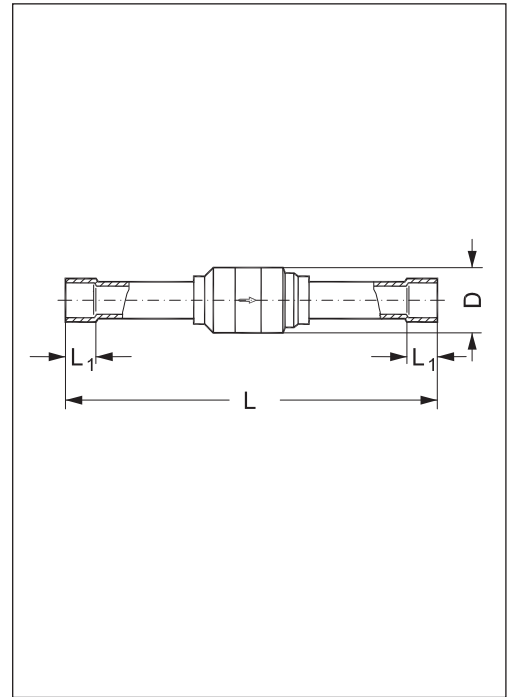

KVR, NRD

Type	Connection				NV ₁	NV ₂	H ₁	H ₂	H ₃	L	L ₁	B ₁	B ₂	C Solder	øD	Net weight
	Flare		Solder ODF													
	[in]	[mm]	[in]	[mm]												
KVR 12	1/2	12	1/2	12	19	19	179	99	66	-	-	64	41	10	30	0.4
KVR 15	5/8	16	5/8	16	24	24	179	99	66	-	-	64	41	12	30	0.4
KVR 22	-	-	7/8	22	-	-	179	99	66	-	-	64	41	17	30	0.4
KVR 28	-	-	1 1/8	28	-	-	259	151	103	-	-	105	48	20	43	1.0
KVR 35	-	-	1 3/8	35	-	-	259	151	103	-	-	105	48	25	43	1.0
NRD	-	-	-	-	-	-	-	-	-	131	10	-	-	-	22	0.1

Danfoss can accept no responsibility for possible errors in catalogues, brochures and other printed material. Danfoss reserves the right to alter its products without notice. This also applies to products already on order provided that such alterations can be made without subsequential changes being necessary in specifications already agreed. All trademarks in this material are property of the respective companies. Danfoss and the Danfoss logotype are trademarks of Danfoss A/S. All rights reserved.